



ambient weather®

SOLAR-POWERED WIRELESS IP WEATHER STATION WITH WEATHER HUB RECEIVER

Model WS-5000-IP3



CONTENTS

Introduction	2
Warnings and Cautions.....	2
Quick Start Guide.....	2
Pre-Installation Checkout and Site Survey.....	3
Getting Started	5
Sensor Array Mounting	9
Rain Gauge Mounting.....	10
Optional Accessories	11
Best Practices for Wireless Communication.....	13
Weather Hub Receiver	14
Connecting to the Weather Hub for Setup.....	15
Weather Services Panel	17
Units Settings Panel	22
Calibration Panel	22
Rain Totals Panel	26
Sensor ID Panel	27
Live Data	28
Glossary of Terms	29
Specifications	31
ARRAY Maintenance	32
Troubleshooting Guide.....	33
Liability Disclaimer.....	35
FCC Statement.....	36
Warranty Information.....	37
California Prop 65	38

INTRODUCTION

Thank you for your purchase of the Ambient Weather WS-5000-IP3 Smart Wireless Weather Station with Remote Monitoring. The following user guide provides step by step instructions for installation, operation, and troubleshooting. To download the latest manual, visit <https://ambientweather.com/manuals.html>. To sign up for firmware or app update alerts, please visit <https://ambientweather.com/firmware-update-alerts>

WARNINGS AND CAUTIONS

WARNING: Any metal object may attract a lightning strike, including your weather station mounting pole. Never install the weather station in a storm.



WARNING: Installing your weather station in a high location may result in injury or death. Perform as much of the initial check out and operation on the ground and inside a building or home. Only install the weather station on a clear, dry day.



QUICK START GUIDE

Although the manual is comprehensive, much of the information contained may be intuitive. In addition, the manual does not flow properly because the sections are organized by components.



The following Quick Start Guide provides only the necessary steps to install, operate the weather station, and upload to the internet, along with references to the pertinent sections.

STEP	DESCRIPTION	PAGE(S)
1	Assemble and power up the outdoor array	5-10
2	Configure and power on any optional sensor(s)	refer to sensor documentation
3	Power up the Weather Hub	14-15
4	Calibrate the relative pressure to sea-level conditions (local airport) on the Weather Hub	22-25
5	Register and connect to weather services	17-19
6	Mount the sensor array and rain gauge	9-10

PRE-INSTALLATION CHECKOUT AND SITE SURVEY

Pre-Installation Checkout

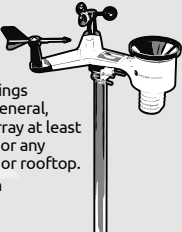
Before installing your weather station in the permanent location, we recommend operating the weather station for one week in a temporary location with easy access. This will allow you to check out all the functions, ensure proper operation, and familiarize you with the weather station and calibration procedures. This will also allow you to test the wireless range of the weather station.

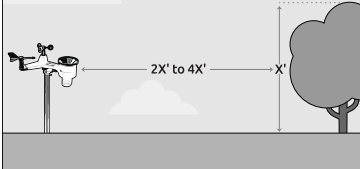
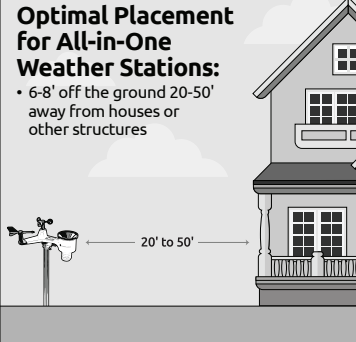
<p>General Guidelines:</p> <ul style="list-style-type: none">• Install in an easily accessible location• Clean the rain gauge every few months• Change batteries every 2-3 years• Avoid radiant heat transfer from buildings and structures. In general, install the sensor array at least 5' from the ground or any building, structure, or rooftop.• Avoid wind and rain obstructions. 	<p>Optimal Placement for Wind Speed Measurement:</p> <ul style="list-style-type: none">• On roof, 8-10' above roofline 
<p>Optimal Placement for Temperature, Humidity, or Rainfall Measurement:</p> <ul style="list-style-type: none">• 4-6' above the ground, horizontal distance 2-4x the height of the nearest object. 	<p>Optimal Placement for All-in-One Weather Stations:</p> <ul style="list-style-type: none">• 6-8' off the ground 20-50' away from houses or other structures 

Site Survey

Perform a site survey before installing the weather station. Consider the following:

1. **Accessibility:** The rain gauge should be cleaned every few months and change the batteries every 2-3 years. Choose a location that provides easy access to the weather station.
2. **Radiant Heat:** Avoid radiant heat transfer from buildings and structures. In general, install the sensor array at least 5' from any building, structure, ground, or roof top.
3. **Avoid Wind and Rain Obstructions:** The rule of thumb is to install the sensor array at least four times the distance of the height of the tallest obstruction. For example, if the building is 20' tall, and the mounting pole is 6' tall, install $4 \times (20-6) = 56'$ away.
4. **Wireless Range:** The radio communication between receiver and transmitter in an open field can reach up to 330 feet, providing there are no interfering obstacles such as buildings, trees, vehicles, high voltage lines. Wireless signals will not penetrate metal buildings. Under most conditions, the maximum wireless range is 100'.
5. **Electromagnetic Signals:** Devices such as PCs, radios, or TV sets can interfere, or in the worst case, entirely cut off radio communication with your array. Please take this into consideration when choosing locations for your Weather Hub receiver the weather array. Make sure your Weather Hub receiver is at least five feet away from any other electronic device(s) to minimize the chance of interference.

Ambient Weather provides the most comprehensive mounting solutions for weather stations, including tripods, pole extensions, pole mounting kits, guy wires, ground stakes and more.

Visit Ambient Weather Mounting Solutions for assistance and ideas for mounting your weather station:

<http://www.ambientweather.com/amwemoso.html>

GETTING STARTED

The Ambient Weather WS-5000-IP Ultrasonic Professional Weather Station consists of one Weather Hub module (RF receiver + IP Module/ Wi-Fi transmitter), one ultrasonic sensor array, one rain gauge, one indoor thermo-hygrometer barometer, and one user manual.

Parts List

Ultrasonic Sensor Array Assembly (Item WS-5000-ARRAY)

QTY	ITEM
1	Ultrasonic sensor array with built-in: thermo-hygrometer / wind speed sensor/ wind direction sensor, light and UV sensor, solar panel
1	Mounting arm
1	Sensor array plastic mounting bracket
1	Mounting screw for connecting sensor array to the mounting pole
4	Threaded nuts for U-Bolts (M5 size)
4	Sensor array lock washers for threaded nuts
2	Sensor array metal mounting plate to be used with U-Bolts
1	Metal wrench for M5 U-Bolts, nuts, and washers

Wireless Rain Collector (Item WS-5000-RAIN)

QTY	ITEM
1	Rain Gauge
4	Threaded nuts for U-Bolts (M5 size)
2	Sensor array metal mounting plate to be used with U-Bolts
1	Metal wrench for M5 U-Bolts, nuts, and washers
1	Funnel coil filter

WeatherHub Assembly (Item WEATHERHUB)

QTY	ITEM
1	Weather Hub Receiver
1	5V DC Adapter
1	Ethernet Cable

Thermo-Hygrometer-Barometer (Item WH32B)

QTY	ITEM
1	Thermo-hygrometer-barometer transmitter
1	Mounting screw
1	Zip tie for non-surface mounting

Included tools

- Allen wrench for Allen head bolt on mounting arm.

Recommend Tools

- Compass or GPS (for wind direction calibration)

#	DESCRIPTION
1	Sonic wind sensor (wind speed and direction)
2	Battery compartment
3	Temperature and humidity sensor
4	Light sensor, LED indicator
5	Solar collector
6	North alignment marker
7	Mounting arm
8	Mounting U-Bolt and bracket.
9	Heater cable
10	Calibration button (factory use only)
11	Reset button

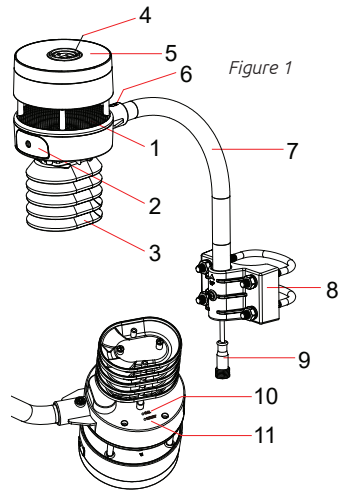

Sensor Array Set Up

Install Batteries

Insert 2×AA batteries into the battery compartment. Alkaline (>4° F) or Lithium batteries for cold weather climates (>-40° F) are recommended.

The LED indicator on the top of the sensor array will turn on for 3 seconds and flash once every 4.75 seconds (the sensor transmission update period).

If the LED does not light up or flash, make sure the battery polarity is correct. Press the reset button.

Install Sensor Array Mounting Arm

Feed heater cable into and through mounting arm (Figure 3).

Attach the mounting arm to the sensor array (Figure 4) using included Allen bolt and hex nut.

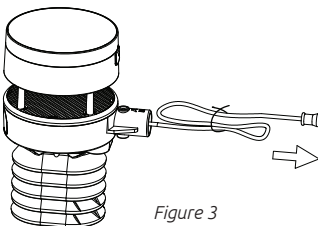
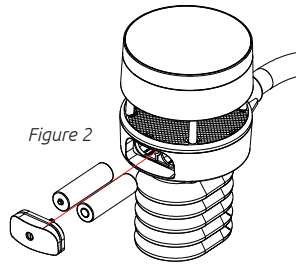

Figure 3

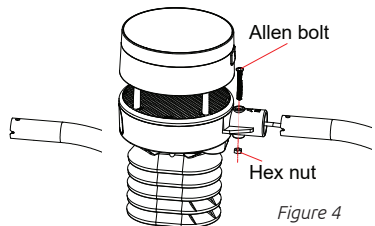
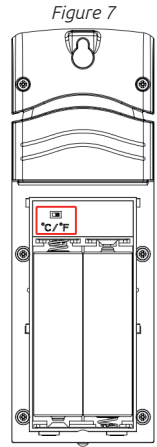
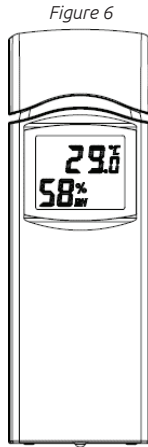
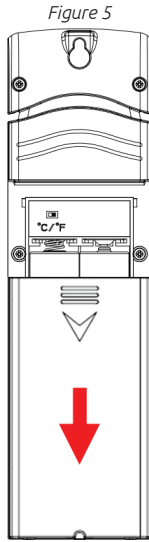

Figure 4

Indoor Thermo-Hygrometer-Barometer Transmitter Set Up

Install Batteries

- Remove the battery door on the back of the sensor (Figure 5).
- Insert Insert 2×AA batteries.
- After inserting the batteries, the remote sensor will display temperature, humidity and barometric pressure on the display (Figure 6).



This sensor is also capable of displaying in Celsius or Fahrenheit by using the switch under the battery door (Figure 7).

#	DESCRIPTION
1	Rain collector and funnel
2	LED indicator
3	Bubble level
4	Battery door
5	Screw hole
6	U-Bolt installation hole

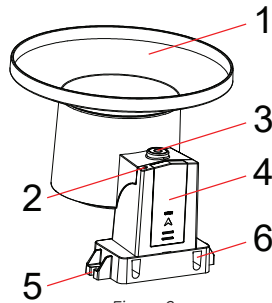

Figure 9

Rain Gauge Set Up

Install Battery

Insert 1×AA battery into the battery compartment. Alkaline (>4° F) or Lithium batteries for cold weather climates (>-40° F) are recommended.

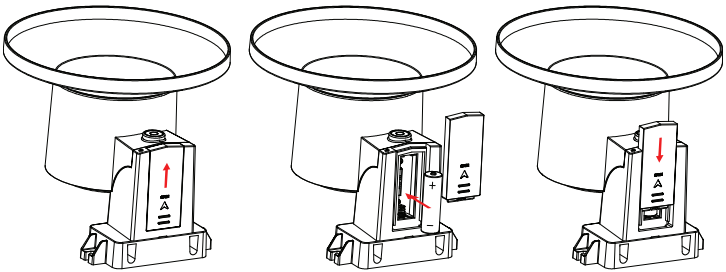

Figure 10

The LED indicator on the top of the rain gauge will turn on for 3 seconds and flash once every 49 seconds (the sensor transmission update period).

If the LED does not light up or flash, make sure the battery polarity is correct. Press the reset button.

Install the Funnel Coil Filter

To install the funnel coil filter, press the coil until the hook is inside the hole at the bottom of the funnel, and locked in place. The spring tension will keep the filter sitting tight on the funnel.

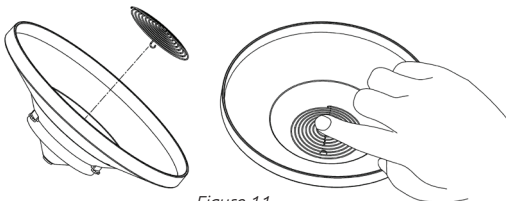
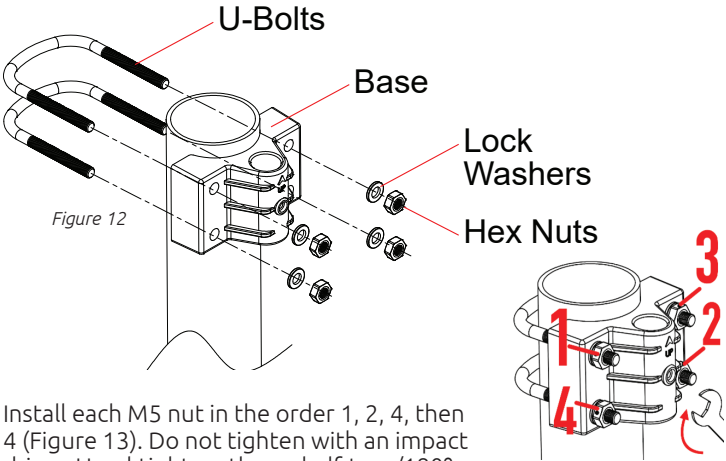

Figure 11

SENSOR ARRAY MOUNTING

Install the sensor array plastic mounting bracket to your 1" to 2" diameter pole, as shown in Figure 12.



Install each M5 nut in the order 1, 2, 4, then 4 (Figure 13). Do not tighten with an impact driver. Hand-tighten, then a half-turn/180°, no more! If your mounting pole is a soft material (wood, PVC, etc.), you may need to retighten the M5 nuts when you perform your maintenance every 3 months.

If the optional ultrasonic heater was purchased, and the heater cable is required, untie, and snake the heater cable through the mounting arm, as shown in Figure 3.

Pass the heater cable through the mounting bracket, as shown in Figure 14.

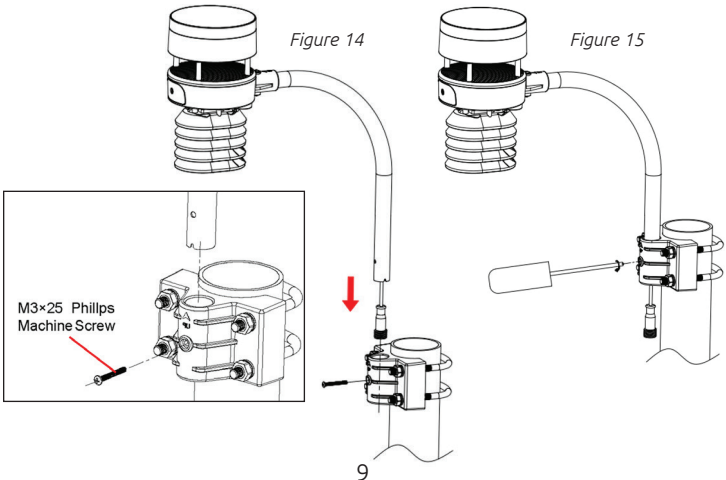

Insert the arm into the base. Align the hole in the base with the hole in the mounting arm and insert the machine screw (Figure 15).

If the optional ultrasonic heater is used, connect the heater cable to the heater, and connect to AC power (Figure 16).

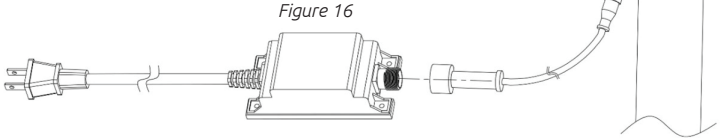

Figure 16

Locate the North marker on the base of the sensor array (Figure 17). Point this marker in the direction of North, according to your GPS or compass.

RAIN GAUGE MOUNTING

Install the sensor array plastic mounting bracket to your 1" to 2" diameter pole, (Figure 18).

To mount to a wooden post or flat surface, use the two included mounting screws (Figure 19).

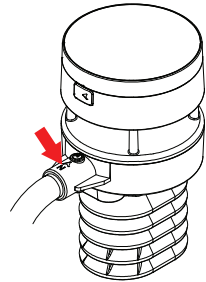

Figure 17

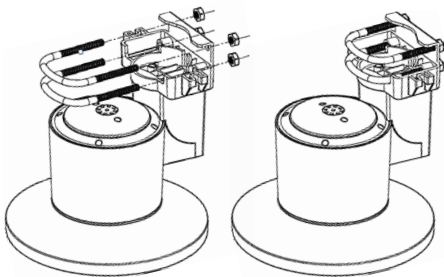

Figure 18

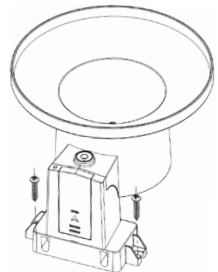



















Figure 19

Use the bubble level next to the rain sensor to make sure the sensor array is completely level.





NOTE: If you cannot read the bubble level due to mounting constraints, place straddle a line or ruler level across the top of the rain gauge for easier viewing.

OPTIONAL ACCESSORIES

DESCRIPTION	PART NUMBER	IMAGE	PRODUCT PAGE
Indoor Air Quality Monitor*	AQIN*		
Outdoor PM25 Particulate Monitor	PM25		
Indoor PM25 Particulate Monitor*	PM25IN*		
Wireless Temperature and Humidity Sensor†	WH31E†		
Indoor Wireless Temperature, Humidity and Pressure Sensor	WH32B		
Leak Detector	WH31LA		
Waterproof Probe Temperature Sensor†	WH31P†		
Soil Moisture Sensor	WH31SM		
Floating Pool Thermometer†	WH31PF†		

* PM25IN and AQIN share the same channel. Only one may be used at any time.

† The WH31E, WH31P and WH31PF share the same 8-channels.

DESCRIPTION	PART NUMBER	IMAGE	
Leaf Wetness Sensor	WH51LW		
Wireless Refrigerator/ Freezer Temperature and Humidity Sensor	WH51RF		

* PM25IN and AQIN share the same channel. Only one may be used at any time.

† The WH31E, WH31P and WH31PF share the same 8-channels.

Adding Additional Sensors

The Weather Hub module supports up to 8 additional thermo-hygrometer sensors (Model WH31E, WH31P, WH31PF). Place the sensors in and around your home and monitor on AmbientWeather.net.

The data is automatically passed from the Weather Hub module to AmbientWeather.net based on the channel number.

The Weather Hub module supports only one indoor (Model PM25IN or AQIN) and one outdoor air quality sensor (Model PM25).

For more information, please visit:

<https://ambientweather.com/faqs/question/tags/tag/PM25/>

Registering Additional Sensors

Please refer to the section “Sensor ID Panel” on page 27.

BEST PRACTICES FOR WIRELESS COMMUNICATION

Wireless communication is susceptible to interference, distance, walls, and metal barriers. We recommend the following best practices for trouble free wireless communication.

Electro-Magnetic Interference (EMI): Keep the console several feet away from computer monitors and TVs.

Radio Frequency Interference (RFI): If you have other 915 MHz devices and communication is intermittent, try turning off these other devices for troubleshooting purposes. You may need to relocate the transmitters or receivers to avoid intermittent communication.

Line of Sight Rating: This device is rated at 300 feet line of sight (no interference, barriers or walls) but typically you will get 100 feet maximum under most real-world installations, which include passing through barriers or walls.

Metal Barriers: Radio frequency will not pass-through metal barriers such as aluminum siding. If you have metal siding, align the remote and console through a window to get a clear line of sight.

The following is a table of reception loss vs. the transmission medium. Each "wall" or obstruction decreases the transmission range by the factor shown below.

MEDIUM	RF SIGNAL STRENGTH REDUCTION
Glass (untreated)	5-15%
Plastics	10-15%
Wood	10-40%
Brick	10-40%
Concrete	40-80%
Metal	90-100%

WEATHER HUB RECEIVER

Requirements:

- Broadband Router: An “always-on” connection to the Internet. A high-speed internet connection that maintains constant connection to the internet.
- AC Power
- Network-connected computer, smart phone, or tablet with a browser

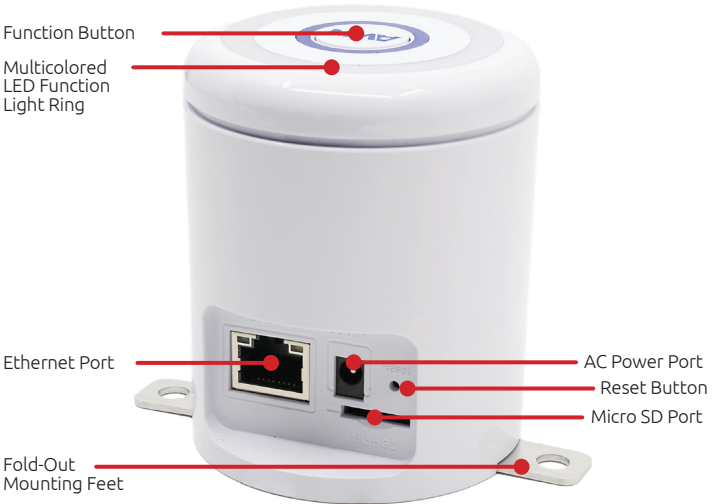

Light and Button Functions

When plugged in, the light illuminates red, green, then blue. Subsequently, it will flash green quickly, then slowly. If the unit does not have WiFi connected yet, it will then illuminate steady green. To put the unit into Wifi configuration broadcast mode, press and hold the center button for 5 seconds. It will then flash green slowly.

Once connected, it will illuminate steady blue. To turn off/on the light while maintaining the function of the unit, short click the center button. To completely reset the unit to factory settings, you may either press the reset button on the rear of the unit with a paper clip, or press and hold the function button for 10 seconds.

CONNECTING TO THE WEATHER HUB FOR SETUP

Connect the Weather Hub receiver power jack to AC power with the power adapter (included).

The Weather Hub can connect to your network via Wi-Fi or directly connected to your router using the included Ethernet cable.

Accessing the Weather Hub Web GUI from your Wi-Fi-Connected Device

Using any computer, smart phone, or tablet with a browser:

Connect to the Wi-Fi network that begins with “WeatherHub-WIFI”.

NOTE: You may be told that the network has no internet connection. Proceed to next step.

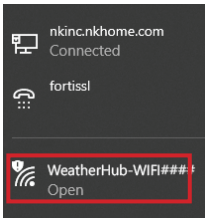

PC Wi-Fi Networks Menu

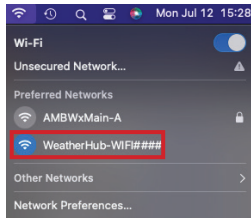

MAC Wi-Fi Selection

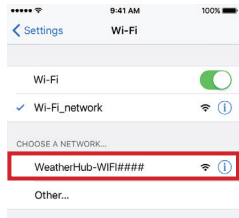

iOS Wi-Fi Selection

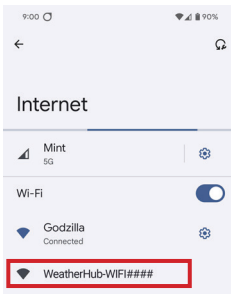

Android Wi-Fi Networks Menu

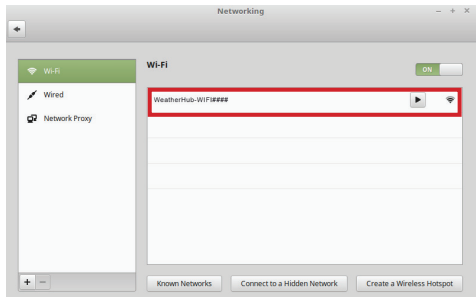

Linux Wi-Fi Networks Menu

Open a browser window and enter 192.168.4.1 in the address bar. You will be presented with the following login screen:

admin

Login

NOTE: Default username is “admin”. No password needed—click “Login.”

Once logged in you will want to navigate to the “Local Network” tab to connect to Wi-Fi and enter your Router SSID and Password:

WiFi Network

Router SSID Your_Router_SSID Scan Router

WiFi Password ***** show password
If you router is dualband, make sure you connect to the router's 2.4GHz band.

IP Address Mode Receive Automatically(DHCP)

Static IP Address 192.168.1.163

Static Subnet Mask 255.255.255.0

Static Gateway 192.168.1.1

Static DNS Server 205.171.3.65

Apply

Accessing the Weather Hub GUI from your Ethernet/LAN-Connected Device

Open a browser window and enter 192.168.4.1 in the address bar. You will be presented with the following login screen:

admin

Login

NOTE: Default username is “admin”. No password needed—click “Login.”

Once logged in you will want to navigate to the the “Local Network” tab to program the local network settings:

MAC: E8:68:E7:12:40:1B

Ethernet Network Settings

IP Address Mode: Receive Automatically(DHCP)

Static IP Address: 0.0.0.0

Static Subnet Mask: 0.0.0.0

Static Gateway: 0.0.0.0

Static DNS Server: 205.171.3.65

Apply

IP Address: The default setting is receiving automatically (DHCP), which is recommended. The network will assign an IP address. To statically assign an IP address, select Static from the pull-down menu. This will prevent the IP address from changing each time you power up the Weather Hub receiver.

Static IP Address: If Static is selected as the IP address, enter the IP address you wish to access the Weather Hub module.

Static Subnet Mask: Default is 255.255.255.0. This should not be changed unless you are familiar with networking and subnet masking.

Static Default Gateway: This is typically the IP address of your router.

If you make any Static IP Address changes (not recommended), to confirm these changes, select Apply and Reboot.

NOTE: *If you incorrectly set the static IP settings and can no longer access the Weather Hub, use a paper clip to access the reset button on the back of the module.*

WEATHER SERVICES PANEL

Select the “Weather Services” tab to program settings for the Ambient Weather Network.

Select preferred update interval and click “Save.” Make a note of the MAC address. It will be required when you add your device to your [AmbientWeather.net](https://www.ambientweather.net) account.

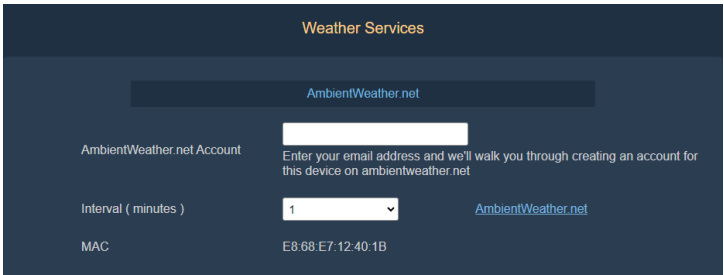

Services such as IFTTT, Amazon Alexa, and Google Assistant can be configured from your AWN dashboard once you have set up your AWN Account. Log in at AmbientWeather.net and go to your Dashboard. Select “Devices” from the left menu, then select the service you want to configure from the row of icons below your Weather Hub device listing.

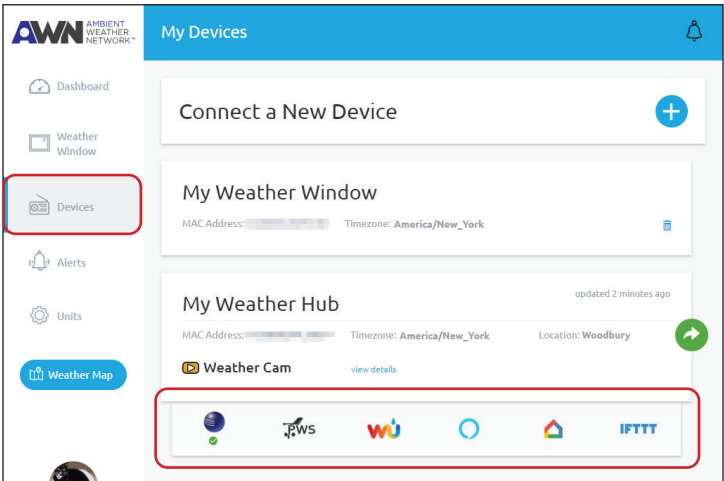

IFTTT

The AmbientWeather.net service connects to IFTTT, the platform that allows devices and services to work together seamlessly.

Here are a few things you can do with IFTTT:

- Turn off your Rachio sprinklers when it rains, there is too much wind, or below freezing.
- Close your Hunter blinds when the sun is too intense.
- Close your garage door when it is too windy.
- Blink your hue lights when it starts raining.

- Connect to other web services, such as Gmail, Facebook, Instagram, or Pinterest.

For more information on IFTTT and how it can work for you, visit: https://ifttt.com/ambient_weather

Compatible with Alexa

The Ambient Weather skill provides Ambient Weather personal weather station owners with the ability to get real-time, and past weather information generated by the devices they have set up at AmbientWeather.net.

Enable the skill and get started: say “Alexa, ask Ambient Weather for a weather report..” This will provide you with your outdoor weather report, but you can ask for your indoor weather report as well by saying, “Alexa, ask Ambient Weather about the indoor conditions.” You can also ask for a report about a specific day, month, or year! Just say “Alexa, ask Ambient Weather about the weather yesterday.” or “Alexa, ask Ambient Weather about the weather in May.”

For more information and to enable this skill, visit: <https://www.amazon.com/dp/B074PGCM1D/>

Works with Google Assistant

The Ambient Weather Google Assistant app provides Ambient Weather personal weather station owners with the ability to get real-time, and past weather information generated by the devices they have set up at AmbientWeather.net

Link your account to get started: say “Hey Google, Ambient Weather... weather report.” This will provide you with your outdoor weather report. You can ask for your indoor weather report as well by saying, “indoor conditions.”

You can also link the Ambient Weather app by downloading the Google Assistant.

Here are some sample commands:

- “Weather Report”
- “Outdoor conditions”
- “Indoor conditions”
- “Yesterday’s weather”
- “Conditions for October 15, 2017”
- “Conditions for September 2017”
- “Conditions for 2016”

For more information and to enable this app, visit: <https://qrco.de/begLJj>

DEVICE SETTINGS PANEL

Be sure to click “Save” to confirm any changes you make in this section.

The screenshot shows a 'Device Setting' panel with the following options:

- Frequency:** A dropdown menu set to 'RFM915MHz'.
- Automatic Frequency Control(AFC):** A toggle switch that is currently turned off.
- Auto Timezone:** A checked checkbox.
- Timezone:** A text field containing 'America/New_York'.
- Date:** A text field containing '12 / 21 / 2023 12 : 26 PM'.
- Upgrade:** A checked checkbox.
- Version:** A section containing the text 'Current version.V2.2.6', a 'Check firmware' button, and a list of updates: '1. Support WN34D temperature sensor (-55~125 °C). 2. Fixed some known bug.'
- Device AP Auto OFF:** A checked checkbox with the description: 'Disable the gateway's self broadcasting SSID after successfully connecting to your own wireless network. This will disable the (OBSERVERIP2-WIFI401B) , used only for device setup.'

A 'Save' button is located at the bottom of the panel.

Access point deactivation

The Weather Hub broadcasts a public Wi-Fi network SSID in order for you to be able to connect to the device for initial setup. We have included the “Device AP Auto OFF” option to turn this off once the device has successfully connected to your Wi-Fi network.

Updating Firmware

You may choose to automatically upgrade firmware by clicking the “Automatically upgrade firmware” checkbox and click “Save.” You may also check for a new version manually.

Time Zone Setting

Enable “Auto Timezone” to allow the device to determine your time zone automatically. Disable to enter your local time zone and daylight Savings Time manually. The following table provides time zones throughout the world. Locations in the eastern hemisphere are positive, and locations in the western hemisphere are negative.

HOURS FROM GMT	TIME ZONE	CITIES
-12	IDLW: International Date Line West	—
-11	NT: Nome	Nome, AK
-10	AHST: Alaska-Hawaii Standard CAT: Central Alaska HST: Hawaii Standard	Honolulu, HI
-9	YST: Yukon Standard	Yukon Territory
-8	PST: Pacific Standard	Los Angeles, CA, USA
-7	MST: Mountain Standard	Denver, CO, USA
-6	CST: Central Standard	Chicago, IL, USA
-5	EST: Eastern Standard	New York, NY, USA
-4	AST: Atlantic Standard	Caracas
-3	—	São Paulo, Brazil
-2	AT: Azores	Azores, Cape Verde Islands
-1	WAT: West Africa	—
0	GMT: Greenwich Mean WET: Western European	London, England
1	CET: Central European	Paris, France
2	EET: Eastern European	Athens, Greece
3	BT: Baghdad	Moscow, Russia
4	—	Abu Dhabi, UAE
5	—	Tashkent
6	—	Astana
7	—	Bangkok
8	CCT: China Coast	Beijing
9	JST: Japan Standard	Tokyo
10	GST: Guam Standard	Sydney
11	—	Magadan
12	IDLE: International Date Line East NZST: New Zealand Standard	Wellington, New Zealand

Daylight Savings Time

If you disable the “Auto Timezone” feature, you will have the option to “Automatically adjust clock for daylight saving time.” Deselect this option if you live in Hawaii or Arizona, where DST is not observed. Enable it if you live anywhere else, even if you are currently observing standard time.

UNITS SETTINGS PANEL

Enter your preferred units of measure for each parameter and click "Save."

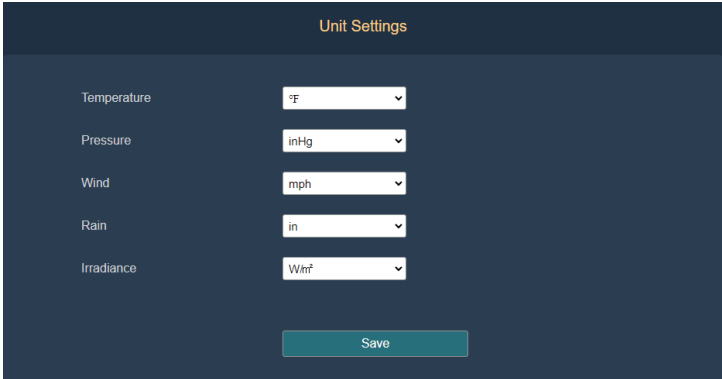

The screenshot shows a dark blue panel titled "Unit Settings" in orange text. It contains five rows, each with a parameter name on the left and a white dropdown menu on the right. The parameters and their selected units are: Temperature (°F), Pressure (inHg), Wind (mph), Rain (in), and Irradiance (W/m²). At the bottom center of the panel is a teal "Save" button.

CALIBRATION PANEL

Select the "Calibration" tab to view your calibration data from the weather station. Calibration of most parameters is not required, except for Relative Pressure, which must be calibrated to sea-level to account for altitude effects. For more information on sea-level pressure calibration, please reference note (3) below.

Relative Barometric Pressure Calibration Example

The following is an example of calibrating the relative pressure. Your results will vary.

1. The local relative pressure from an official station (via TV, radio, newspaper, or internet) in your area is 30.12 inHg.
2. On the Live Data panel, the absolute pressure reading from your station or sensor (not corrected to sea-level) reads 28.90 inHg.
3. Use the following formula to determine the value to enter into the Calibration panel for Relative Pressure Offset:

$$30.12 \text{ (official reading)} - 28.90 \text{ (measured reading)} = 1.22$$

Calibration

Irradiance Gain	<input style="width: 90%;" type="text" value="1.00"/>	Range: 0.10 - 5.00
UV Gain	<input style="width: 90%;" type="text" value="1.00"/>	Range: 0.10 - 5.00
Wind Gain	<input style="width: 90%;" type="text" value="1.00"/>	Range: 0.10 - 5.00
InTemp Offset	<input style="width: 90%;" type="text" value="0.0"/>	°F
InHumi Offset	<input style="width: 90%;" type="text" value="0"/>	%
Abs Offset	<input style="width: 90%;" type="text" value="0.00"/>	inHg
Rel Offset	<input style="width: 90%;" type="text" value="0.23"/>	inHg
OutTemp Offset	<input style="width: 90%;" type="text" value="0.0"/>	°F
OutHumi Offset	<input style="width: 90%;" type="text" value="0"/>	%
WindDir Offset	<input style="width: 90%;" type="text" value="0"/>	Degress

Save

Reset to Defaults

PARAMETER	TYPE OF CALIBRATION	DEFAULT	TYPICAL CALIBRATION SOURCE
Temperature	Offset	Current Value	Red Spirit or Mercury Thermometer (1)
Humidity	Offset	Current Value	Sling Psychrometer (2)
ABS Barometer	Offset	Current Value	Calibrated laboratory grade barometer
REL Barometer	Offset	Current Value	Local airport (3)
Wind Direction	Offset	Current Value	GPS, Compass (4)
Solar Radiation	Gain	1.00	Calibrated laboratory grade solar radiation sensor
UV	Gain	126.7 lux	Solar radiation conversion from lux to w/m2 for wavelength correction (5)
Wind	Gain	1.00	Calibrated laboratory grade wind meter (6)
Rain	Gain	1.00	Sight glass rain gauge with an aperture of at least 4" (7)

- Temperature errors can occur when a sensor is placed too close to a heat source (such as a building structure, the ground, or trees).

To calibrate temperature, we recommend a mercury or red spirit (fluid) thermometer. Bi-metal (dial) and digital thermometers (from other weather stations) are not a good source and have their own margin of error. Using a local weather station in your area is also a poor source due to changes in location, timing (airport weather stations are only updated once per hour) and possible calibration errors (many official weather stations are not properly installed and calibrated).

Place the sensor in a shaded, controlled environment next to the fluid thermometer, and allow the sensor to stabilize for 48 hours. Compare this temperature to the fluid thermometer and adjust the Weather Hub receiver to match the fluid thermometer.

- Humidity is a difficult parameter to measure electronically and drifts over time due to contamination. In addition, location has an adverse effect on humidity readings (installation over dirt vs. lawn for example).

Official stations recalibrate or replace humidity sensors on a yearly basis. Due to manufacturing tolerances, the humidity is accurate to $\pm 5\%$. To improve this accuracy, the indoor and outdoor humidity can be calibrated using an accurate source, such as a sling psychrometer.

- The Weather Hub receiver displays two different pressures: absolute (measured) and relative (corrected to sea-level).

To compare pressure conditions from one location to another, meteorologists correct pressure to sea-level conditions. Because the air pressure decreases as you rise in altitude, the sea-level corrected pressure (the pressure your location would be at if located at sea-level) is generally higher than your measured pressure.

Thus, your absolute pressure may read 28.62 inHg (969 mb) at an altitude of 1000 feet (305 m), but the relative pressure is 30.00 inHg (1016 mb).

The standard sea-level pressure is 29.92 in Hg (1013 mb). This is the average sea-level pressure around the world. Relative pressure measurements greater than 29.92 inHg (1013 mb) are considered high pressure and relative pressure measurements less than 29.92 inHg are considered low pressure.

To determine the relative pressure for your location, locate an official reporting station near you and set your weather station to match the official reporting station.

- Only use this if you improperly installed the weather station sensor array and did not point the direction reference to true north.
- The default conversion factor based on the wavelength for bright sunlight is 126.7 lux/w/m². This variable can be adjusted by photovoltaic experts based on the light wavelength of interest, but for most weather station owners, is accurate for typical applications, such as calculating evapotranspiration and solar panel efficiency.
- Wind speed is the most sensitive to installation constraints. The rule of thumb for properly installing a wind speed sensor is 4× the distance of the tallest obstruction. For example, if your house is 20' tall and you mount the sensor on a 5' pole:

$$\text{Distance} = 4 \times (20' - 5') = 60'$$

Many installations are not perfect and installing the weather station on a roof can be difficult. Thus, you can calibrate for this error with a wind speed multiplier.

In addition to the installation challenges, wind cup bearings (moving parts) wear over time.

Without a calibrated source, wind speed can be difficult to measure. We recommend using a calibrated wind meter (available from Ambient Weather) and a constant speed, high speed fan.

- The rain collector is calibrated at the factory based on the funnel diameter. The bucket tips every 0.01" of rain (referred to as resolution). The accumulated rainfall can be compared to a sight glass rain gauge with an aperture of at least 4". The following is a link to an accurate sight glass rain gauge:

<http://www.ambientweather.com/stprraga.html>

Make sure you periodically clean the rain gauge funnel.

NOTE: *The purpose of calibration is to fine tune or correct for any sensor error associated with the devices margin of error. Errors can occur due to electronic variation (example, the temperature sensor is a resistive thermal device or RTD, the humidity sensor is a capacitance device), mechanical variation, or degradation (wearing of moving parts, contamination of sensors).*

Calibration is optional and only useful if you have a known calibrated source you can compare it against. This section discusses practices, procedures, and sources for sensor calibration to reduce manufacturing and degradation errors. Do not compare your readings obtained from sources such as the internet, radio, television, or newspapers. The purpose of your weather station is to measure conditions of your hyperlocal surroundings, which vary significantly from location to location.

RAIN TOTALS PANEL

Rain Totals

Rainfall data priority ▼
Choose which rain gauge data upload to server and display.

Rain Day in

Rain Week in

Rain Month in

Rain Year in

Rain Gain
Range: 0.10 - 5.00

Reset Daily Rain at ▼

Reset Weekly Rain at ▼

Rainfall Season ▼

During the installation of your weather station, you may report false rain due to vibration of the tipping mechanism. To reset the rain to 0.00, select the "Reset" button as shown above, or enter the Daily, Weekly, Yearly, Monthly and Yearly rain totals in the appropriate fields, and select "Save."

During rain gauge cleaning, the tipping mechanism may record false rain. Before rain gauge cleaning, record the rain totals before and after the cleaning procedure, then correct the daily, weekly, monthly, and yearly totals.

SENSOR ID PANEL

The Weather Hub can pair with up to 8 additional thermo/hygrometer sensors (Model WH31E, WH31P, WH31PF). Place the sensors in and around your home and monitor on AmbientWeather.net.

The data is automatically passed from the Weather Hub to AmbientWeather.net based on the channel number.

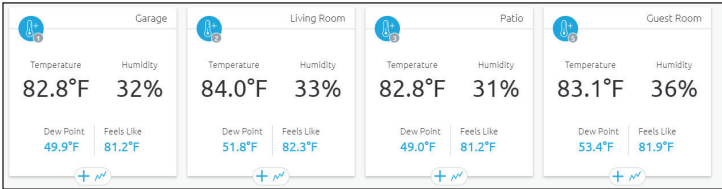

Registering Additional Sensors

Please refer to the product documentation for each optional sensor for directions on configuring and operation.

Once your sensors are configured and powered on, log in to the Weather Hub web GUI (see pages 15-17) and access the “Sensors ID” tab.

On the Sensors ID screen, you can register or re-register an additional sensor by clicking the “Re-register” button.

	Name	ID	Battery	Signal	Re-register	Operating
	WS2000	0xED	---	▼	Re-register	Edit
	5kRAIN	0x1379D	---	▼	Re-register	Edit
	WH32B	0x72	---	▼	Re-register	Edit
	WH32E	Learning	---	▼	Re-register	Edit
	WS5000	0x27A4	---	▼	Re-register	Edit
	Lightning	0xD126	---	▼	Re-register	Edit
	AQIN	0x444B	---	▼	Re-register	Edit
	PM2.5 OUT	Learning	---	▼	Re-register	Edit

LIVE DATA

Select the “Live Data” tab to view your live data from your weather station and other sensors.

The screenshot displays a 'Live Data' interface with a dark blue background. On the left is a vertical navigation menu with the following items: Local Network, Weather Services, Device Setting, Unit Settings, Calibration, Rain Totals, Sensors ID, Live Data (highlighted), and Version: WH2682B_V2.0.3. The main content area is titled 'Live Data' and contains several data cards. The top row shows Outdoor Temperature (71.8 °F), Outdoor Humidity (45%), and Feel Like (71.8 °F). The second row shows Dew point (49.3 °F), Wind chill (71.8 °F), and Wind Speed (0.00 mph). The third row shows Gust Speed (0.00 mph), Day Wind Max (0.00 mph), and Solar Radiation (0.00 w/m²). The fourth row shows UV-Index (0) and Wind Direction (0° with a green arrow icon). Below these is a row with Indoor Temperature (78.6 °F), Indoor Humidity (36%), Absolute Pressure (28.71 in-Hg), and Relative Pressure (30.04 in-Hg). At the bottom is a 'Rain' section with a table of cumulative and rate data.

Rain	
Rain Event	0.00 in
Rain Rate	0.00 in/Hr
Rain Day	0.00 in
Rain Week	0.00 in
Rain Month	0.00 in
Rain Year	0.00 in

GLOSSARY OF TERMS

TERM	DEFINITION
Absolute Barometric Pressure	Absolute pressure is the measured atmospheric pressure and is a function of altitude, and to a lesser extent, changes in weather conditions. Absolute pressure is not corrected to sea-level conditions. Refer to Relative Barometric Pressure.
Accuracy	Accuracy is defined as the ability of a measurement to match the actual value of the quantity being measured.
Barometer	A barometer is an instrument used to measure atmospheric pressure.
Calibration	Calibration is a comparison between measurements – one of known magnitude or correctness of one device (standard) and another measurement made in as similar a way as possible with a second device (instrument).
Dew Point	The dew point is the temperature at which a given parcel of humid air must be cooled, at constant barometric pressure, for water vapor to condense into water. The condensed water is called dew. The dew point is a saturation temperature. The dew point is associated with relative humidity. A high relative humidity indicates that the dew point is closer to the current air temperature. Relative humidity of 100% indicates the dew point is equal to the current temperature and the air is maximally saturated with water. When the dew point remains constant and temperature increases, relative humidity will decrease.
Hectopascals (hPa)	Pressure units in SI (international system) units of measurement. Same as millibars (1 hPa = 1 mbar)
Hygrometer	A hygrometer is a device that measures relative humidity. Relative humidity is a term used to describe the amount or percentage of water vapor that exists in air.
Inches of Mercury (inHg)	Pressure in Imperial units of measure. 1 inch of mercury = 33.86 millibars
Rain Gauge	A rain gauge is a device that measures liquid precipitation (rain), as opposed to solid precipitation (snow gauge) over a set period. All digital rain gauges are self-emptying or self-dumping (also referred to as tipping rain gauge). The precision of the rain gauge is based on the volume of rain per emptying cycle.
Range	Range is defined as the amount or extent a value can be measured.
Relative Barometric Pressure	Measured barometric pressure relative to your location or ambient conditions.
Resolution	Resolution is defined as the number of significant digits (decimal places) to which a value is being reliably measured.

Solar Radiation	<p>A solar radiation sensor measures solar energy from the sun.</p> <p>Solar radiation is radiant energy emitted by the sun from a nuclear fusion reaction that creates electromagnetic energy. The spectrum of solar radiation is close to that of a black body with a temperature of about 5800 K. About half of the radiation is in the visible short-wave part of the electromagnetic spectrum. The other half is mostly in the near-infrared part, with some in the ultraviolet part of the spectrum.</p>
Thermometer	<p>A thermometer is a device that measures temperature. Most digital thermometers are resistive thermal devices (RTD). RTDs predict change in temperature as a function of electrical resistance.</p>
Wind Vane	<p>A wind vane is a device that measures the direction of the wind. The wind vane is usually combined with the anemometer. Wind direction is the direction from which the wind is blowing.</p>

SPECIFICATIONS

Wireless Specifications

Line of sight wireless transmission (in open air): 330 feet, 100 feet under most conditions

Outdoor Sensor Update Rate: 16 seconds

Indoor Sensor Update Rate: 64 seconds

Frequency: 915 MHz

Measurement Specifications

The following table provides the specifications for the measured parameters.

MEASUREMENT	RANGE	ACCURACY	RESOLUTION
Indoor Temperature	14°F–140°F	±2°F	0.1°F
Outdoor Temperature	-40°F–149°F (lithium batteries)		
-23°F–140°F (alkaline batteries)	±2°F	0.1°F	
Indoor Humidity	10 to 99%	±5%	1 %
Outdoor Humidity	10 to 99%	±5%	1 %
Barometric Pressure	8.85 to 32.50 inHg	±0.08 inHg (within range of 27.13 to 32.50 inHg)	0.01 inHg
Light	0 to 200,000 Lux	±15%	1 Lux
Rain	0 to 394 in.	±5%	0.01 in
Wind Direction	0 - 360 °	±10°	1°
Wind Speed	0 to 100 mph (operational)	±2.2 mph or 10% (whichever is greater)	1.4 mph

Power Consumption

Weather Hub Receiver: 5V DC Adapter (included)

Outdoor Sensor Array: 2× AA batteries (not included; we suggest Energizer Lithium)

Rain Gauge: 1× AA battery (not included; we suggest Energizer Lithium)

ARRAY MAINTENANCE

1. Clean the rain gauge once every 3 months. Rotate the funnel counter-clockwise and lift to expose the rain gauge mechanism (Figure 11), and clean with a damp cloth. Remove any dirt, debris and insects. If bug infestation is an issue, spray the array lightly with insecticide.
2. Clean the solar radiation sensor and solar panel every 3 months with damp cloth.
3. Replace batteries every 1-2 years. If left in too long, the batteries may leak due to environmental challenges. In harsh environments, inspect the batteries every 3 months (when cleaning the solar panel).
4. When replacing the batteries, apply a corrosion preventive compound on the battery terminals, available at Amazon and most hardware stores.
5. In snowy environments, spray the top of the weather station with anti-icing silicone spray to prevent snow buildup.

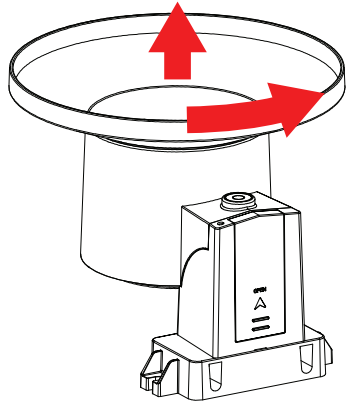

Figure 11

TROUBLESHOOTING GUIDE

If your question is not answered here, you can contact us as follows:

Email Support: support@ambientweather.com

Technical Support: 480-346-3380 (M-F 8am to 3pm Arizona Time)

PROBLEM	SOLUTION
Wireless remote (thermo-hygrometer) not reporting in to Weather Hub Receiver.	<p>The maximum line of sight communication range is about 300'. Move the sensor assembly closer to the Weather Hub receiver.</p> <p>Install a fresh set of batteries in the remote sensor(s).</p> <p>Make sure the remote sensors are not transmitting through solid metal (acts as an RF shield), or earth barrier (down a hill).</p> <p>Radio Frequency (RF) Sensors cannot transmit through metal barriers (example, aluminum siding) or multiple, thick walls.</p> <p>Move the Weather Hub receiver around electrical noise generating devices, such as computers, TVs and other wireless transmitters or receivers.</p>
Outdoor sensor array does not communicate to the Weather Hub Receiver.	<p>The sensor array may have initiated improperly, and the data is registered by the Weather Hub receiver as invalid. The sensor array must be reset. The reset button is next to the LED, near the mounting point on the sensor array.</p> <p>With an open-ended paperclip, press the reset button for 3 seconds to completely discharge the voltage.</p> <p>Take out the batteries and wait one minute, while covering the solar panel to drain the voltage.</p> <p>Put batteries back in and resync with Weather Hub receiver by powering down and up the Weather Hub receiver with the sensor array about 10 feet away.</p> <p>Bring the sensor array inside the house (you can disconnect it from the rest of the sensors). The LED next to the battery compartment will flash every 16 seconds. If the LED is not flashing every 16 seconds, replace the batteries in the outside sensor array. Non-rechargeable batteries are preferred for testing purposes.</p> <p>If the batteries were recently replaced, check the polarity. If the sensor is flashing every 48 seconds, proceed to the next step.</p> <p>There may be a temporary loss of communication due to reception loss related to interference or other location factors, or the batteries may have been changed in the sensor array and the Weather Hub receiver has not been reset. The solution may be as simple as powering down and up the Weather Hub.</p> <p>Replace the batteries in the outside sensor array. Non-rechargeable batteries are preferred for testing purposes.</p> <p>With the sensor array and Weather Hub 10 feet away from each other, remove AC power from the Weather Hub receiver and wait 10 seconds. Re-connect power.</p>

<p>Absolute pressure does not agree with official reporting station</p>	<p>You may be viewing the relative pressure, not the absolute pressure.</p> <p>Select the absolute pressure. Make sure you properly calibrate the sensor to an official local weather station. Reference page 22 for details.</p>
<p>Temperature sensor reads too high in the day time.</p>	<p>Make certain that the sensor array is not too close to heat generating sources or structures, such as buildings, pavement, walls or air conditioning units. Use the calibration feature to offset installation issues related to radiant heat sources.</p>
<p>Rain gauge reports rain when it is not raining</p>	<p>An unstable mounting solution (sway in the mounting pole) may result in the tipping bucket incorrectly incrementing rainfall. Make sure you have a stable, level mounting solution.</p>
<p>Wind vane does not spin as freely as the wind cups.</p>	<p>This is by design. The dampening prevents the wind vane from spinning with the slightest breeze, which will result in variable wind all of the time. The added resistance allows the wind vane to change direction with 2 – 3 mph, providing a much better wind direction tracking.</p>
<p>Time off by increments of an hour, or date is off by one day.</p>	<p>The time zone is entered incorrectly. Reference pages 20-21.</p>
<p>Data not reporting to Wunderground.com</p>	<p>Confirm your password is correct. It is the password you registered on Wunderground.com. Your Wunderground.com password cannot begin with a non-alphanumeric character (a limitation of Wunderground.com, not the station). Example, \$oewkrf is not a valid password, but oewkrf\$ is valid.</p> <p>Confirm your station ID is correct. The station ID is all caps, and the most common issue is substituting an O for a 0 (or vice versa). Example, KAZPHOEN11, not KAZPH0EN11.</p> <p>Make sure your time zone is set properly. If incorrect, you may be reporting old data, not real time data.</p> <p>Check your router firewall settings. The Weather Hub sends data via Port 80.</p>

LIABILITY DISCLAIMER

- Please help in the preservation of the environment and return used batteries to an authorized depot.
- The electrical and electronic wastes contain hazardous substances. Disposal of electronic waste in wild country and/or in unauthorized grounds strongly damages the environment.
- Reading this user manual is highly recommended. The manufacturer and supplier cannot accept any responsibility for any incorrect readings and any consequences that occur should an inaccurate reading take place.
- This product is designed for use in the home only as indication of weather conditions. This product is not to be used for medical purposes or for public safety information.
- The specifications of this product may change without prior notice.
- This product is not a toy. Keep out of the reach of children.
- No part of this manual may be reproduced without written authorization of the manufacturer.
- Ambient, LLC WILL NOT ASSUME LIABILITY FOR INCIDENTAL, CONSEQUENTIAL, PUNITIVE, OR OTHER SIMILAR DAMAGES ASSOCIATED WITH THE OPERATION OR MALFUNCTION OF THIS PRODUCT.

FCC STATEMENT

Statement according to FCC part 15.19:

This device complies with part 15 of the FCC rules. Operation is subject to the following two conditions:

- This device may not cause harmful interference.
- This device must accept any interference received, including interference that may cause undesired operation.

Statement according to FCC part 15.21:

Modifications not expressly approved by this company could void the user's authority to operate the equipment.

Statement according to FCC part 15.105:

NOTE: This equipment has been tested and found to comply with the limits for a Class B digital device, pursuant to Part 15 of the FCC Rules. These limits are designed to provide reasonable protection against harmful interference in a residential installation. This equipment generates, uses, and can radiate radio frequency energy and, if not installed and used in accordance with the instructions, may cause harmful interference to radio communications.

However, there is no guarantee that interference will not occur in a particular installation. If this equipment does cause harmful interference to radio or television reception, which can be determined by turning the equipment off and on, the user is encouraged to try to correct the interference by one or more of the following measures:

- Reorient or relocate the receiving antenna.
- Increase the separation between the equipment and receiver.
- Connect the equipment into an outlet on a circuit different from that to which the receiver is connected.

Consult a dealer or an experienced radio/TV technician for help.

WARRANTY INFORMATION

Ambient, LLC provides a 1-year limited warranty on this product against manufacturing defects in materials and workmanship.

This limited warranty begins on the original date of purchase, is valid only on products purchased and only to the original purchaser of this product. To receive warranty service, the purchaser must contact Ambient, LLC for problem determination and service procedures.

Warranty service can only be performed by an Ambient, LLC. The original dated bill of sale must be presented upon request as proof of purchase to Ambient, LLC.

Your Ambient, LLC warranty covers all defects in material and workmanship with the following specified exceptions: (1) damage caused by accident, unreasonable use or neglect (lack of reasonable and necessary maintenance); (2) damage resulting from failure to follow instructions contained in your owner's manual; (3) damage resulting from the performance of repairs or alterations by someone other than an authorized Ambient, LLC authorized service center; (4) units used for other than personal use (5) applications and uses that this product was not intended (6) the products inability to receive a signal due to any source of interference or metal obstructions and (7) extreme acts of nature, such as lightning strikes or floods.

This warranty covers only actual defects within the product itself and does not cover the cost of installation or removal from a fixed installation, normal set-up or adjustments, claims based on misrepresentation by the seller or performance variations resulting from installation-related circumstances.

CALIFORNIA PROP 65

WARNING: *Use of this AWN product can expose you to chemicals, including lead and lead compounds, which are known to the State of California to cause cancer and bisphenol A (BPA), and phthalates DINP and/or DEHP, which are known to the State of California to cause birth defects or other reproductive harm.*

Can I Trust that AWN Products are Safe Despite this Warning?

In 1986, California voters approved the Safe Drinking Water and Toxic Enforcement Act known as Proposition 65 or Prop 65. The purpose of Proposition 65 is to ensure that people are informed about exposure to chemicals known by the State of California to cause cancer, birth defects and/or other reproductive harm. A company with ten or more employees that operates within the State of California (or sells products in California) must comply with the requirements of Proposition 65. To comply, businesses are: (1) prohibited from knowingly discharging listed chemicals into sources of drinking water; and (2) required to provide a “clear and reasonable” warning before knowingly and intentionally exposing anyone to a listed chemical. Proposition 65 mandates that the Governor of California maintain and publish a list of chemicals that are known to cause cancer, birth defects and/or other reproductive harm. The Prop 65 list, which must be updated annually, includes over 1,000 chemicals, including many that are commonly used in the electronics industry.

Although our manufacturing process is “lead-free” and RoHS compliant, it remains possible that trace amounts of lead could be found in components or subassemblies of AWN Products. Bisphenol A (BPSA) could conceivably be present in minute amounts in our plastic housings, lenses, labels, or adhesives, and DEHP & DINP (phthalates) could possibly be found in PVC wire coatings of our cables, housings, and power cords. Unlike RoHS, Prop 65 does not establish a specific threshold for reporting on the substances of concern and instead sets forth a much less definitive standard requiring that the business demonstrate with certainty that there is “no significant risk” resulting from exposure. With respect to carcinogens, the “no significant risk” level is defined as the level which is calculated to result in not more than one excess case of cancer in 100,000 individuals exposed over a 70-year lifetime. In other words, if you are exposed to the chemical in question at this level every day for 70 years, theoretically, it will increase your chances of getting cancer by no more than 1 case

in 100,000 individuals so exposed. With respect to reproductive toxicants, the “no significant risk” level is defined as the level of exposure which, even if multiplied by 1,000, will not produce birth defects or other reproductive harm. In other words, the level of exposure is below the “no observable effect level,” divided by 1,000. (The “no observable effect level” is the highest dose level which has not been associated with observable reproductive harm in humans or test animals.) Proposition 65 does not clarify whether exposure is to be measured only in normal operation, or in the event of misuse such as intentionally damaging, incinerating or consuming an AWN Product or component and Ambient Weather has not attempted to evaluate the level of exposure.

A Proposition 65 warning means one of two things: (1) the business has evaluated the exposure and has concluded that it exceeds the “no significant risk level”; or (2) the business has chosen to provide a warning simply based on its knowledge about the presence of a listed chemical without attempting to evaluate the exposure. **The California government has itself clarified that “The fact that a product bears a Proposition 65 warning does not mean by itself that the product is unsafe.” The government has also explained, “You could think of Proposition 65 more as a ‘right to know’ law than a pure product safety law.”**

While using AWN Products as intended, we believe any potential exposure would be negligible or well within the “no significant risk” range. However, to ensure compliance with California law and our customers’ right to know, we have elected to place the Proposition 65 warning signs on AWN Products.

For further information about California’s Proposition 65, please visit <https://oehha.ca.gov/prop65/background/p65plain.html>

CUSTOMER SERVICE

Email Support:
support@ambientweather.com

Technical Support:
480-346-3380 (M-F 8am to 4pm Arizona Time)

©Copyright 2024, Ambient LLC. All Rights Reserved.



MADE IN CHINA